

# PRIME

PINNACLE

OWNER'S MANUAL

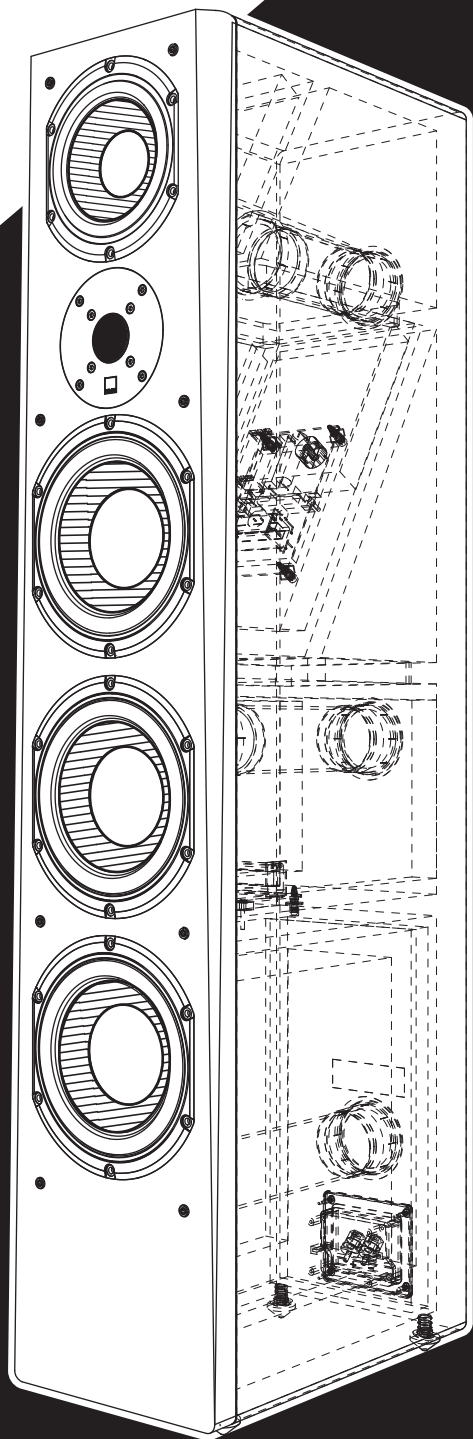

SOUND  
| EVOLUTION





## *Thank you, and congratulations on choosing the SVS Prime Pinnacle speakers!*

All it takes is one listen to Prime Pinnacle and you'll understand the passion we have for acoustic engineering and more importantly, thrilling and immersive audio experiences. Leveraging design and technology from the reference SVS Ultra Series Speakers, Prime Pinnacle features high-performance drivers and sophisticated crossover components typically found in loudspeakers costing many times more. We're proud to say that you won't find better sound quality, dynamic output or high-end loudspeaker design elements anywhere near the price.

If you ever have any questions about your SVS product, or need help setting them up, please contact the SVS Sound Experts.

**[www.svsound.com](http://www.svsound.com) • [custservice@svsound.com](mailto:custservice@svsound.com) • (877) 626-5623**

Happy Listening!

**Setting Up Your Prime Speakers..... 3**  
    Foot Options..... 3  
    Acoustics & Room Placement..... 4  
    Room Placement..... 5  
    Connecting Your Speakers..... 6

**Caring for Your Prime Speakers..... 7**  
**Warranty & Support..... 7**  
**Share Your Thoughts..... 7**  
**Features & Specifications..... 8**

### Foot Options

The Prime Pinnacle speakers come packaged with two sets of foot support options that allow optimal placement on a variety of floor surfaces. The Elastomer Isolation Feet that come pre-installed on the Prime Pinnacle speakers can be removed (unscrew to remove) and replaced with the included Threaded Metal Spike Kit. Both sets of feet are threaded to allow easy leveling of the Prime Pinnacles if they should stand on an uneven surface.

#### *Elastomer Isolation Feet*

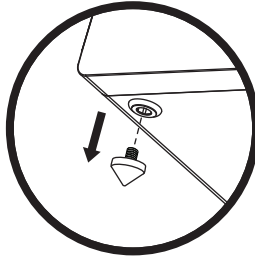

#### *Threaded Metal Spikes*

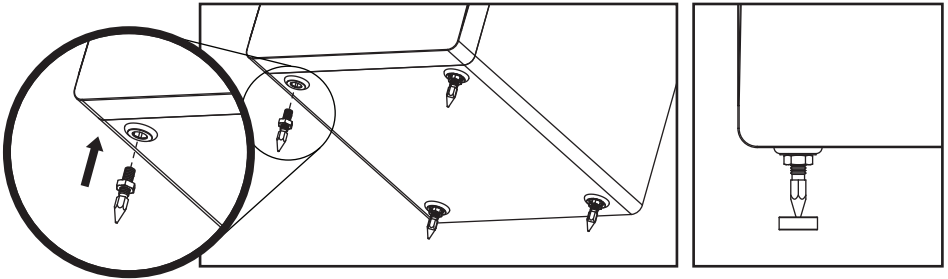

### Acoustics & Room Placement:

Proper placement of the front left/right speakers is essential to achieve the smoothest frequency response, optimal stereo imaging and the most spacious, three-dimensional soundstage.

Stereo imaging and soundstage are affected by loudspeaker location and the listening position, relative to each other and room boundaries. Moving the loudspeakers away from room boundaries will tend to improve stereo imaging and spaciousness by attenuating and delaying boundary reflections, thus optimizing direct sound and helping to preserve spatial information in the recording.

The amount of exposed glass, drywall and bare floor in the room will increase the amount of reflected sound and can influence the sound quality of any loudspeaker system. Furnishings like carpeting, drapes and upholstered furniture will reduce the amount of reflected sound in the room. Dedicated room treatments like absorbers, diffusers and bass traps can also improve the sound quality of a listening environment and only serve to enhance the performance of a speaker system, sometimes dramatically.

SVS recommends starting with the front loudspeakers located 30-degrees to the left and right (i.e., a 60-degree total window) of the listening position.

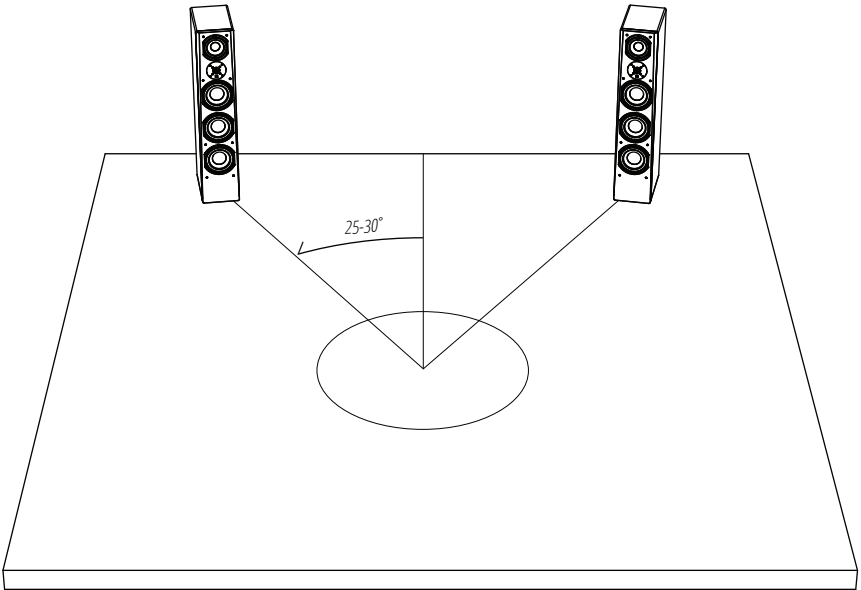

**Room Placement:**

Toeing-in the loudspeakers 5-10 degrees can often improve imaging, however this is also a function of the distance from nearby boundaries and the ratio of direct-to-reflected sound, so experimentation with toe-in is recommended to obtain optimal results.

The location of the front loudspeakers relative to nearby boundaries will excite various room modes (a complex pattern of standing waves with associated peaks and nulls), which will affect the bass response of the loudspeakers.

Generally, placing the loudspeakers closer to room boundaries (particularly corners) will increase the bass response. Conversely, moving the loudspeakers away from boundaries and corners will reduce the bass response. Due to the complex interaction of the loudspeakers with nearby boundaries/corners and your listening position, significant changes to the bass response can occur with very small changes in either loudspeaker location or listening position, so experimentation with both placement and listening position is recommended to obtain optimal results.

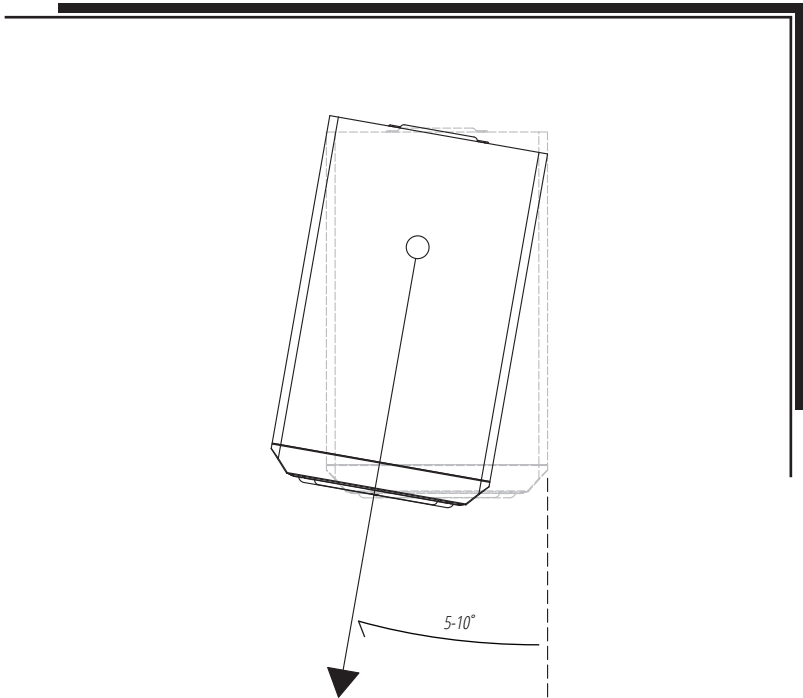

Please contact the SVS Sound Experts if you have any questions or concerns about placement of your Prime Pinnacle speakers.

**Connecting Your Speakers:**

Prime Pinnacle speakers include terminals with convenient gold-plated 5-way binding posts that accept wires and cables terminated with banana plugs, speaker pins, spade connectors and bare wire. Simply connect each loudspeaker to the appropriate amplifier channel of your receiver or power amplifier.

To ensure proper performance of your speakers, always be sure to maintain proper +/- polarity between the speaker and the amplifier or AV receiver.

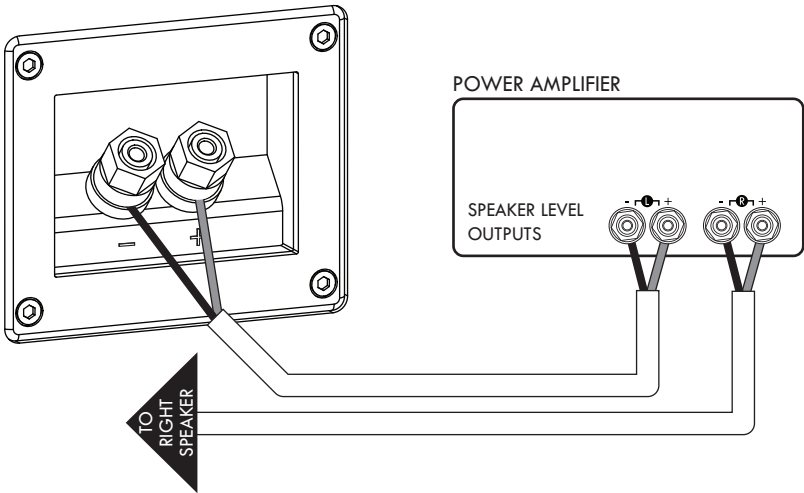



Your Prime Speakers may be gently cleaned as follows:

- Use a dry microfiber duster to remove any loose surface dust.
- Use a water-damp microfiber cloth to remove fingerprints, smudges and other contaminants. Wipe in one direction only, with the grain if applicable.
- Follow any damp cleaning immediately with a dry microfiber cloth. Again dry wipe in one direction only, with the grain if applicable.

## WARRANTY & SUPPORT

### 5-YEAR UNCONDITIONAL WARRANTY

SVS offers the industry's most comprehensive warranty on all our products. SVS warrants these Prime Pinnacle speakers and all of their products to be free from defects in the workmanship for 5 years from date of purchase.

This, and all of the SVS customer Bill of Rights can be viewed online at:

[www.svsound.com/bill-of-rights](http://www.svsound.com/bill-of-rights).

## SHARE YOUR THOUGHTS

Our SVS Sound Experts are standing by from Monday to Friday from 9AM-9PM ET, Saturday from 12PM-6PM, and Sunday from 12PM-4PM to assist you with speaker set-up and optimization, AV Receiver settings and more. They can be reached by phone, email or chat via the options below.

[www.svsound.com](http://www.svsound.com) • [custservice@svsound.com](mailto:custservice@svsound.com) • (877) 626-5623

We also invite you to share a review on our website and to join our fun and active social media community where we share reviews, featured systems, interesting audio articles and more.



Post at [facebook.com/SVSound](https://facebook.com/SVSound)



Watch at [youtube.com/c/SVS\\_Sound](https://youtube.com/c/SVS_Sound)



Follow [instagram.com/SVS\\_Sound](https://instagram.com/SVS_Sound)



Tweet @[SVS\\_Sound](https://twitter.com/SVS_Sound)

*Specifications are subject to change. SVS is constantly working to improve our products and give you the best listening experience possible.*

## **PRIME PINNACLE**

### **Frequency Response and Electro-Acoustic Data:**

- Rated bandwidth: 29 Hz-25 kHz (+/-3 dB).
- Nominal impedance: 8 ohms.
- Sensitivity: 88 dB (2.83V @ 1 meter full-space, 300-3kHz).
- Recommended amplifier power: 20-300 watts.

### **Loudspeaker Physical Description:**

- Premium Black Ash and Piano Gloss Black finish options.
- 5-way binding posts.
- Triple 2" wide-flared rear-firing ports.
- Cloth grille with pin/cup retention system.
- Cabinet Dimensions: 40.5" (H) X 8" (W) X 13.4" (D).
- Overall Dimensions: 41.1" (H) X 8" (W) X 13.9" (D) (includes grille, feet and binding posts).
- Weight Packaged: 66 lbs. (29.9 kg)
- Weight Unboxed: 57.1 lbs. (25.9 kg)

### **Driver Array and Technical Highlights:**

- 1" tweeter features FEA-optimized diffuser and aluminum dome.
- 5.25" all new midrange driver features composite glass-fiber cone, aluminum shorting ring, cast ABS-fiberglass composite basket and vented voice coil former.
- Triple 6.5" woofers feature long stroke motor and suspension, polypropylene cone, aluminum shorting ring, cast ABS-fiberglass composite basket and vented voice coil former.

### **SoundMatch Crossover Network:**

- 3-way crossover with premium-grade capacitors, air-core inductors and heavy-trace printed circuit boards.
- 2-piece PCB design reduces component interference.
- Tweeter-to-Midrange crossover: 2.1kHz (12 dB/octave slopes).
- Midrange-to-Woofer crossover frequency: 300Hz (12 dB/octave slopes).

### **Cabinet Construction Technical Highlights:**

- Separate sealed midrange enclosure with angled bracing diffuses and shifts standing waves beyond the driver pass band, improving sound quality.
- Three separate woofer enclosures with optimized port tuning frequencies for smooth and accurate bass response.
- Acoustically transparent and FEA optimized grilles minimize diffraction.
- Chamfered front baffle and flush-mounted drivers reduce edge diffraction and improved on-axis high frequency response.
- FEA-optimized cabinet and angled bracing eliminates resonances and improves cabinet rigidity for acoustically inert enclosure.





SVS  
260 Victoria Rd.  
Youngstown, Ohio 44515  
United States  
(877) 626-5623  
[www.svsound.com](http://www.svsound.com)